

# Turkish - American Clean Energy Conference

January 29 - 30, 2008, İstanbul, Turkey

CLEAN COAL / HYDROELECTRIC / WIND / SOLAR / BIO-FUEL

## **FLUE GAS DESULPHURIZATION IN A VENTURI-BAFFLE-SPRAY SCRUBBING SYSTEM WITH CALCIUM MAGNESIUM ACETATE SOLUTION**

**Bekir Zühtü Uysal**

**Department of Chemical Engineering  
and  
Director of Clean Energy Research and Application Center  
Gazi University  
06570 Ankara, Turkey**

**Consultant of Turkish Coal Enterprises  
Hipodrom Cad., No.12, Yenimahalle, 06330 Ankara, Turkey**

## FGD Systems

DRY

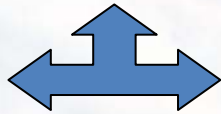

WET

Lime Scrubbing ( $\text{Ca(OH)}_2$ )  
Limestone Scrubbing ( $\text{CaCO}_3$ )  
Welman Lord Scrubbing ( $\text{NaSO}_3$ )  
Dual-Alkali Scrubbing ( $\text{NaOH}$ ,  $\text{NaCO}_3$ ,  $\text{NaSO}_3$ )  
Magnesium Based Scrubbing ( $\text{MgO}$ )  
Ammonia Based Scrubbing ( $\text{NH}_3$ )

K.Wark, C. F. Warner, W. T. Davis, "Air Pollution – Its Origin and Control"

K. B. Schnelle, C. A. Brown, "Air Pollution Control Technology Handbook"

L. G. Rich, "Environmental Systems Engineering"

# Turkish - American Clean Energy Conference

January 29 - 30, 2008, Istanbul, Turkey

CLEAN COAL / HYDROELECTRIC / WIND / SOLAR / BIO-FUEL

**Main problem in FGD Scrubbers : Clogging,  
scale deposits,**

*B. Z. Uysal*



## Solubilities of some components involved in FGD

	<i>Solubility [g/100 g water]</i>
$\text{NaHCO}_3$	6,9
$\text{Na}_2\text{CO}_3$	7,1
<b>CMA</b>	<b>26</b>
$\text{Ca}(\text{OH})_2$	0,185
$\text{Mg}(\text{OH})_2$	0,0009

## CALCIUM MAGNESIUM ACETATE (CMA)

- CMA is friendly with environment
- CMA is useful to overcome the plugging of liquid lines
- High solubilities (26% by weight)
- High concentration of calcium ions in the liquid phase according to lime or limestone solutions
- High SO<sub>2</sub> removal efficiency

## Stoichiometry of Calcium Magnesium Acetate (CMA) Preparation

### Analysis of Lime

%CaO	95,55
%MgO	0,9
%Other	3,55

CaO : 2,77 kg  
MgO : 0,026 kg

HAc : 7.47 kg

H<sub>2</sub>O : 20,02 kg

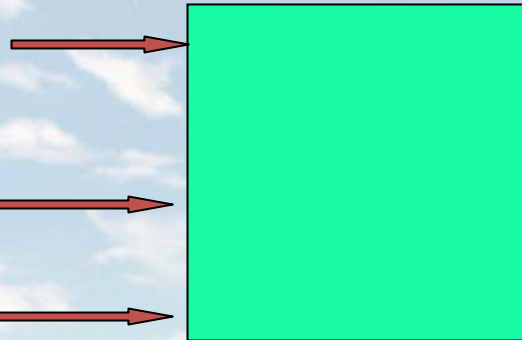

CaAc<sub>2</sub> : 7,86 kg

H<sub>2</sub>O : 22,42 kg

# Turkish - American Clean Energy Conference

January 29 - 30, 2008, İstanbul, Turkey

CLEAN COAL / HYDROELECTRIC / WIND / SOLAR / BIO-FUEL

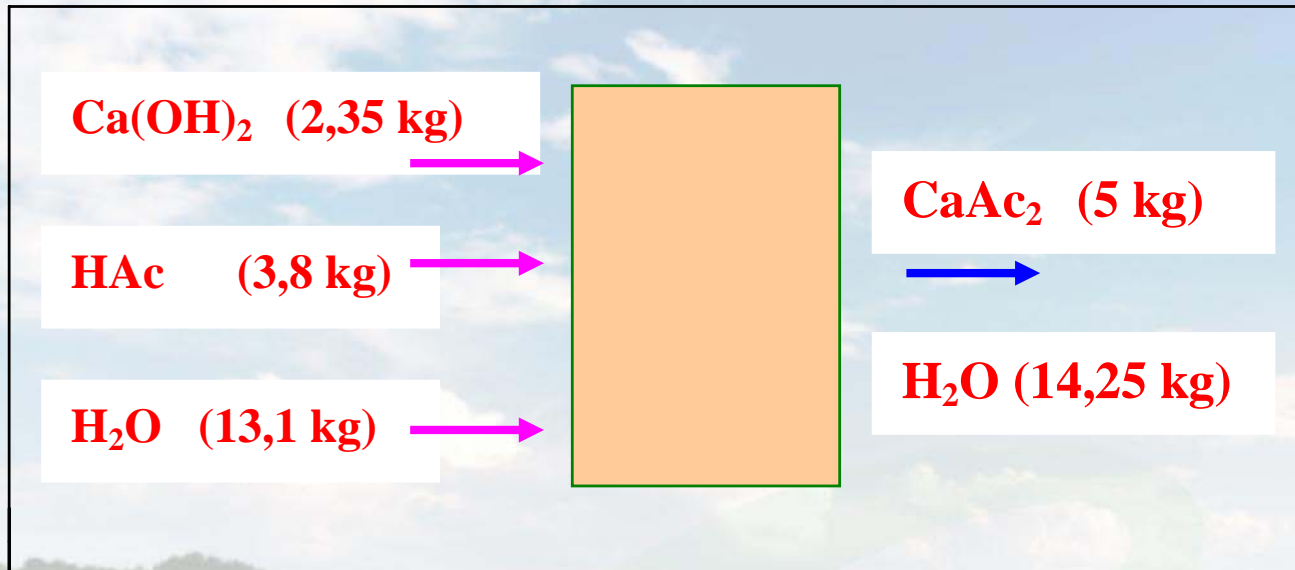

B. Z. Uysal



## Reaction Mechanism of Calcium Acetate With $\text{SO}_2$

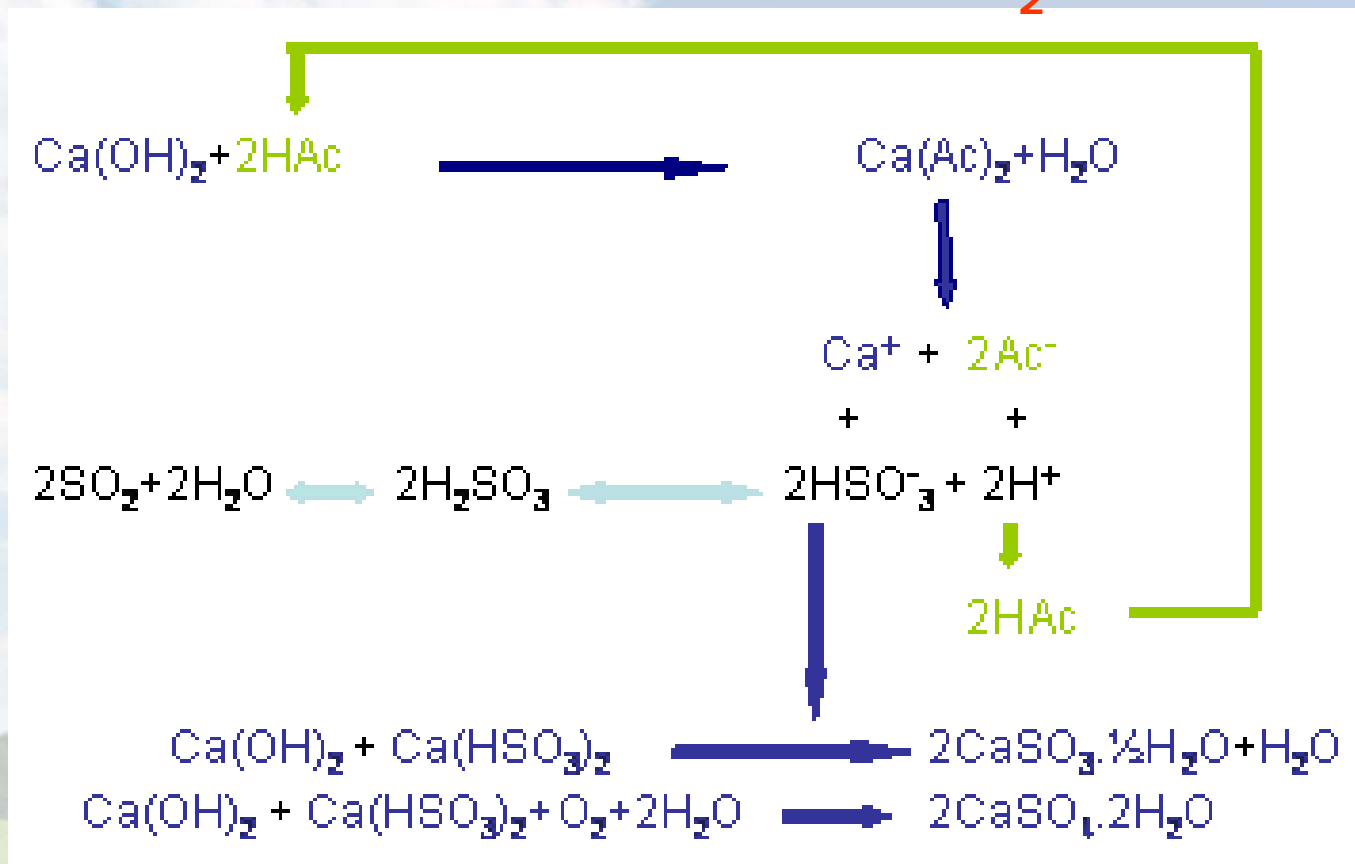

# Turkish - American Clean Energy Conference

January 29 - 30, 2008, İstanbul, Turkey

CLEAN COAL / HYDROELECTRIC / WIND / SOLAR / BIO-FUEL

## Scrubbing System

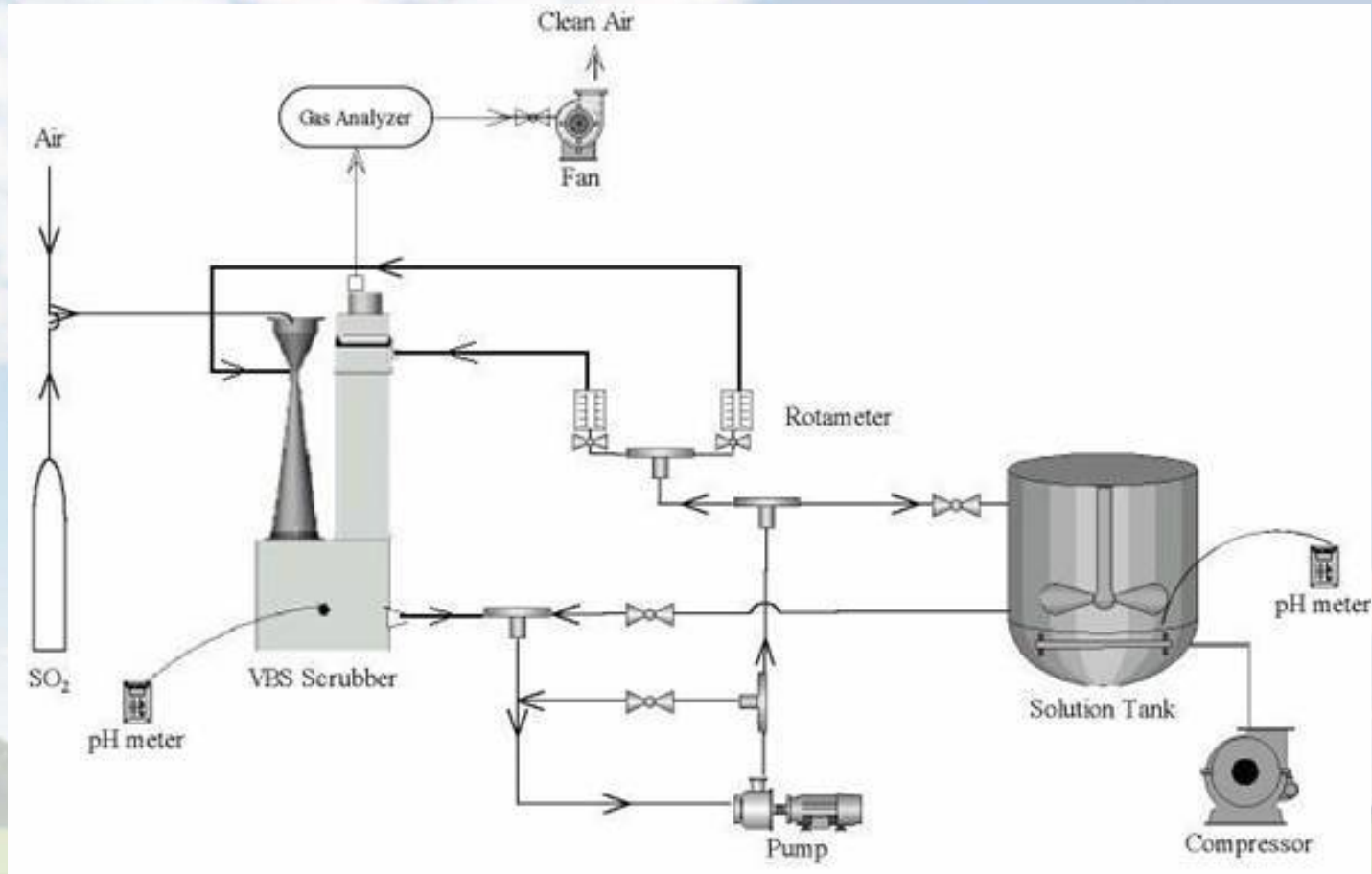

B. Z. Uysal



# Turkish - American Clean Energy Conference

January 29 - 30, 2008, Istanbul, Turkey

CLEAN COAL / HYDROELECTRIC / WIND / SOLAR / BIO-FUEL

## VBS Scrubber

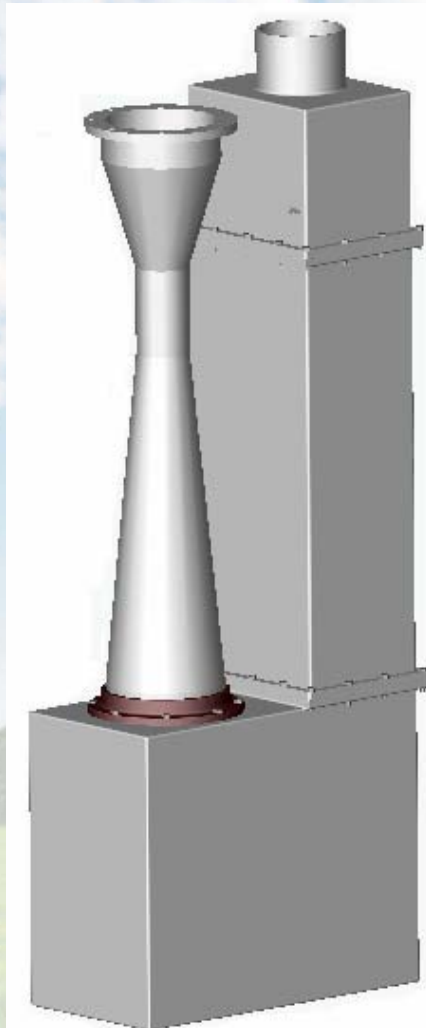

### •Venturi

$D_{\text{throat}} = 50 \text{ mm}$

$L = 1 \text{ m}$



### •Baffle

$L_{\text{Baffle}} = 300 \text{ mm}$

Tank : 500x300x500 mm

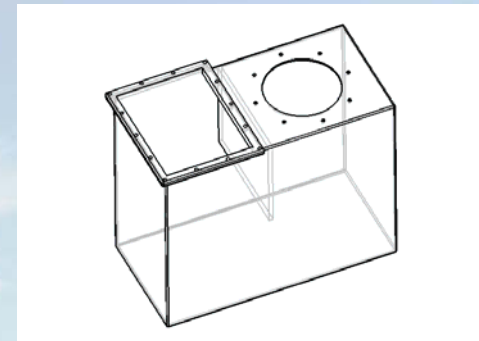

### •Spray Column

Active Height = 750 mm

Width = 300 mm

Depth = 250 mm

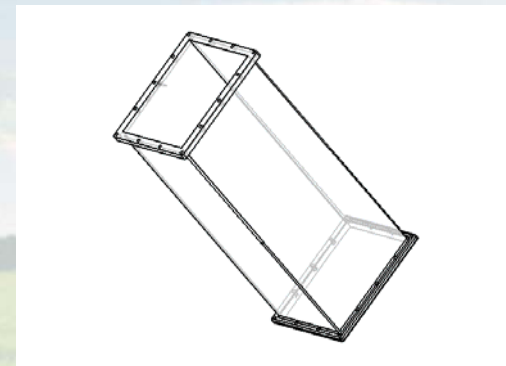

B. Z. Uysal



## Pressure Loss in Dry System

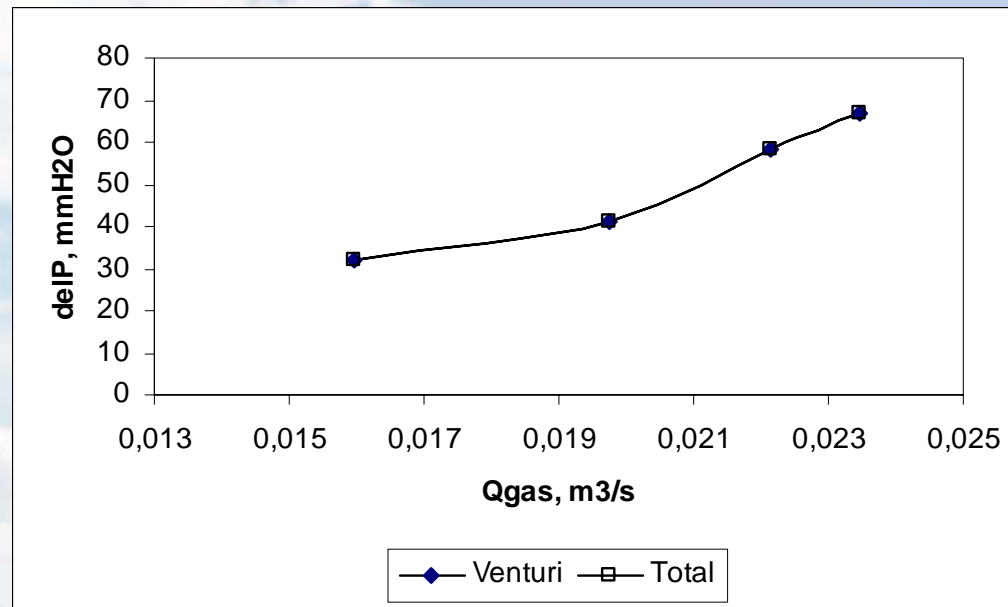

## Effect of Gas Flow Rate on SO<sub>2</sub> Removal Efficiency in Scrubbing With 0.126 M CMA Solution

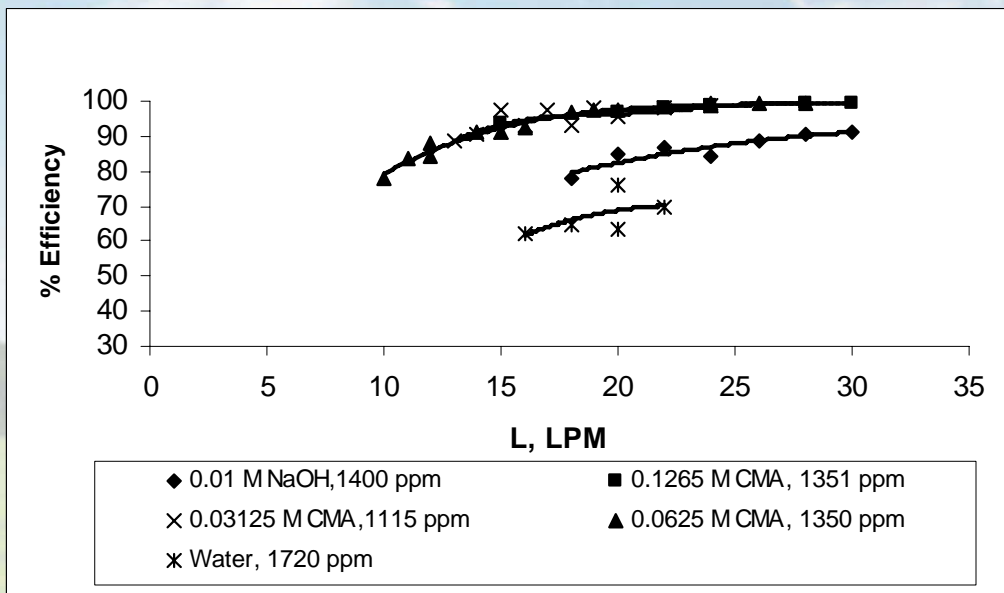
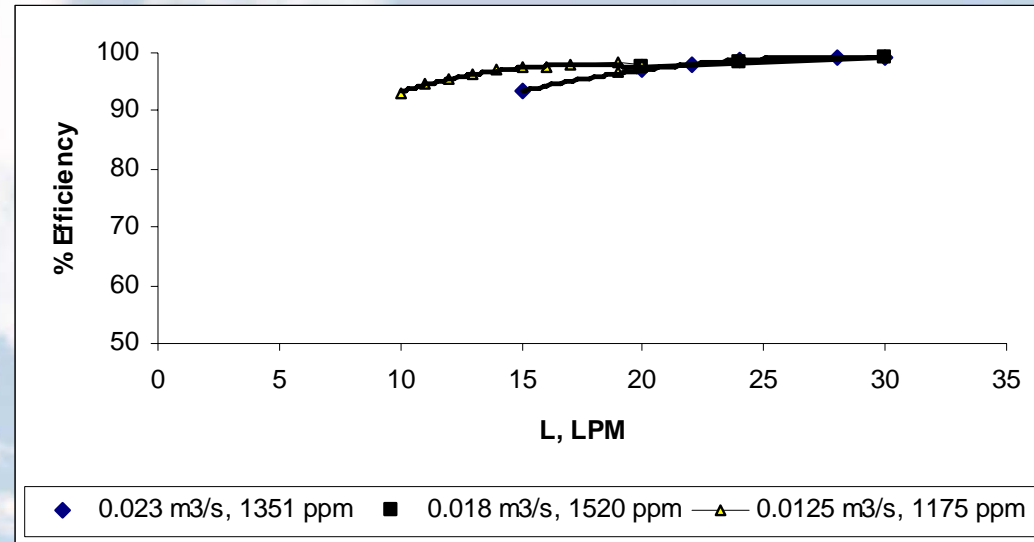

## Effect of Liquid Flow Rate on SO<sub>2</sub> Removal Efficiency

## Reaction Mechanism of Calcium Acetate With SO<sub>2</sub>

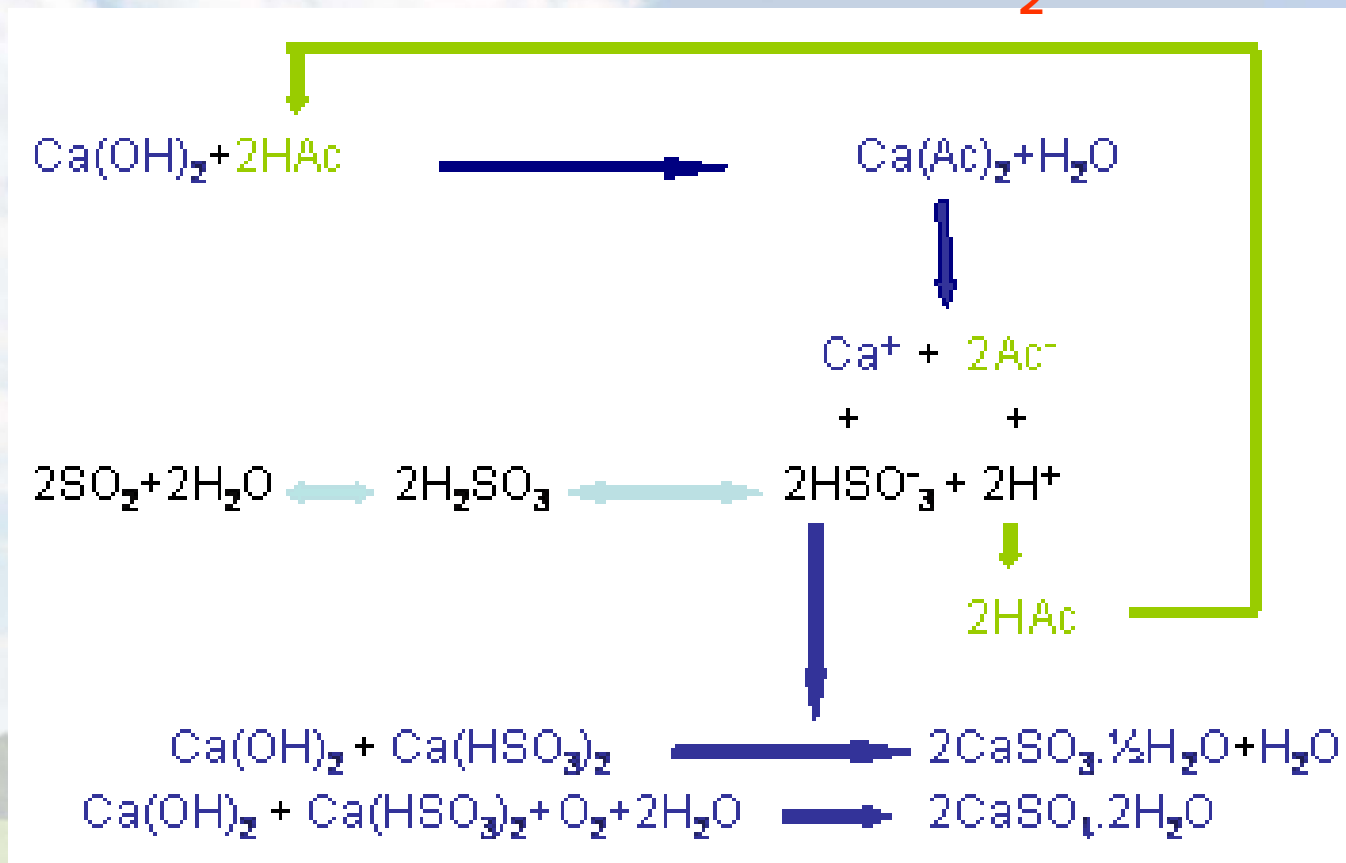

## Regeneration of CMA solution during the absorption $\text{SO}_2$ in VBS scrubber.

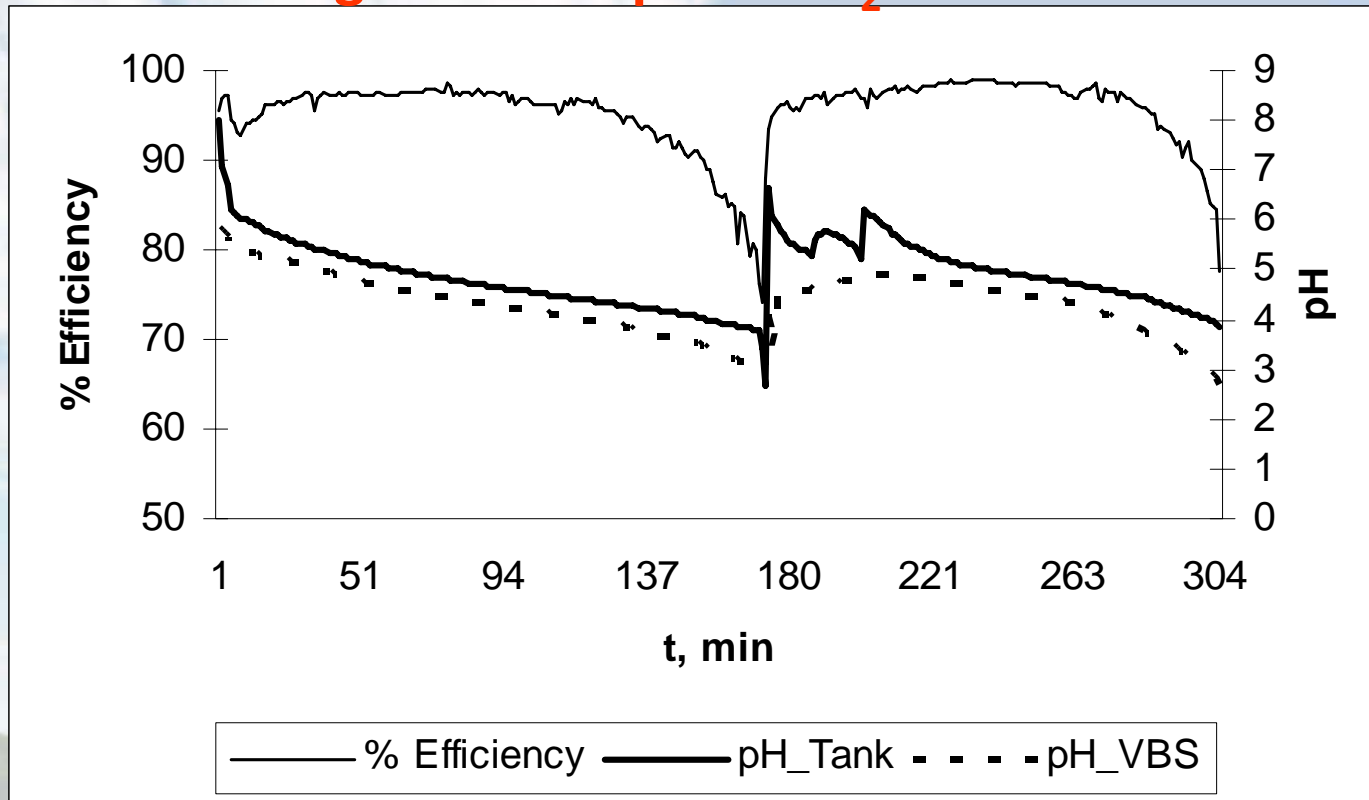

(Inlet gas concentration = 1770 ppm  $\text{SO}_2$ , liquid flow rate = 20 LPM,  
initial CMA concentration = 0.035 M)

## CONCLUSIONS

- It was possible to reach much higher efficiencies with CMA solutions than NaOH solution and water .
- There was practically no effect of gas flow rate and CMA concentration in the liquid on the efficiency
- Some increase in the efficiency was observed with the increase in liquid flow rate and the SO<sub>2</sub> removal efficiency reached about 98% for liquid flow rates greater than 20 LPM .
- Regeneration of spent solution with Ca(OH)<sub>2</sub> was also achieved during 5 hour long tests. This suggests the possibility of lowering the operating cost of the scrubbing process.

# Turkish - American Clean Energy Conference

January 29 - 30, 2008, Istanbul, Turkey

CLEAN COAL / HYDROELECTRIC / WIND / SOLAR / BIO-FUEL

*Thank you for your attention.*

B. Z. Uysal



## Reactions

### Overall reactions :

From Ca(OH)<sub>2</sub> point of view:



## Reactions

Fom Ca(Ac)<sub>2</sub> point of view:



# Turkish - American Clean Energy Conference

January 29 - 30, 2008, İstanbul, Turkey

CLEAN COAL / HYDROELECTRIC / WIND / SOLAR / BIO-FUEL

*B. Z. Uysal*

